



ONE SYSTEMS®

# Pan and Tilt Bracket Installation

PT-70-2, PT-35-2 and PT-10 (Issued November 2009)

**WARNING: DO NOT attempt to mount multiple brackets side by side using the same stainless steel banding system. The stainless steel banding systems are designed for use with ONE bracket ONLY!**

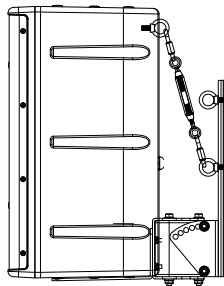

PT-35-2 with 108IM

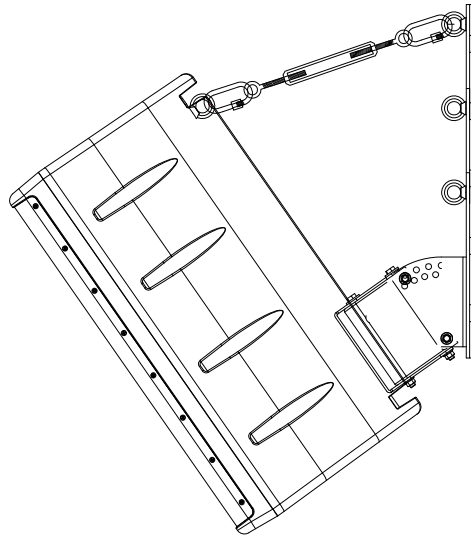

PT-70-2 with 112IM

The PT-70-2, PT-35-2 and PT-10 are easy to install and flexible systems designed to allow ONE SYSTEMS loudspeaker products to be mounted to wall and certain pole structures. The PT-10 instructions are found at the end of this document. The only products approved for use with the PT-70-2 and PT-35-2 includes the following:

**PT-70-2**

- 112IM
- 112IM-70
- 112IM-100
- 212CIM
- 212CIM-70
- 212CIM-100
- 212IM
- 212IM-70
- 212IM-100
- 312CIM
- 312CIM-70
- 312CIM-100
- CFA
- CFA-70
- CFA-100
- 115TW

**PT-35-2**

- 108IM
- 108IM-70
- 108IM-100
- 208CIM
- 208CIM-70
- 208CIM-100

**PT-10**

- 103IM
- 103IM-70
- 103IM-100
- 106IM
- 106IM-70
- 106IM-100

**NOTE:** The 112UM is also compatible with the PT-70-2, but a user supplied stainless steel wire rope assembly is required in place of the Link assembly for 10 degrees or less down tilt. The wire rope diameter should be 3/32 inch (2.5mm) or larger.

### **NO OTHER LOUDSPEAKERS SHOULD BE SUBSTITUTED!**

The following actions **MUST** be performed **PRIOR** to beginning the installation of the PT-70-2, PT-35-2 or PT-10:

1. This installation guide must be completely read and understood
2. The instruction manual ***“Rigging and Suspension of One Systems Products”*** must be read and understood. (This instruction manual is available with other technical papers at [www.onesystems.com](http://www.onesystems.com) by clicking on the “Documentation” tab on the home page, then by clicking “Educational Papers”
3. The structure of the mating surface **MUST** be capable of supporting the combined weight of the pan and tilt bracket, the loudspeaker and all associated rigging; and must satisfy the required safety factors specified by local and national codes, as well as safe rigging practices.
4. The PT-70-2, PT-35-2 and PT-10 pan and tilt brackets should be installed only by someone experienced in the overhead suspension of items. They should be familiar with applicable local/national codes governing the installation of these types of products and those governing the attachment of these types of products to specific pole structures.

**CAUTION:** All structures outdoors are subjected to wind forces. These forces must be considered when suspending any product outdoors. It is necessary to know the “Effective Projected Area” (EPA) of the loudspeaker prior to installation of the loudspeaker and the PT-70-2, PT-35-2 or PT-10. See Appendix 1 of this installation manual for effective projected areas for each enclosure rated for use with the PT-70-2, PT-35-2 and PT-10.

# INSTALLATION

**NOTE:** See separate instructions for the PT-10 later in this document

The PT-70-2 and PT-35-2 consist of three parts: the wall bracket, the loudspeaker bracket, and the Link. The PT-70-2 wall bracket and loudspeaker bracket are shown in Figure 1. Figure 1a shows the wall bracket portion of the PT-70-2. The PT-70-2 bracket allows the loudspeaker to be oriented from a 0 degree down tilt to a maximum down tilt of 35 degrees in 5 degrees increments. The PT-35-2 allows a down tilt of 40 degrees in 8 degree increments.

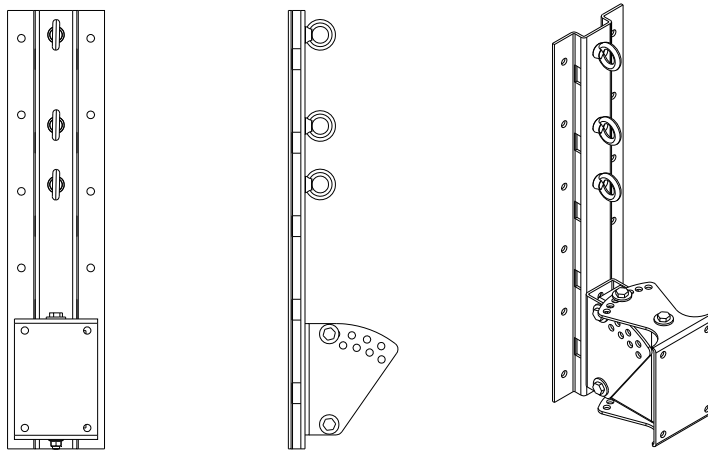

Figure 1

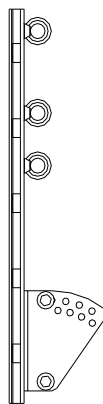

Figure 1a

The PT-35-2 wall bracket and loudspeaker bracket are shown in Figure 2.

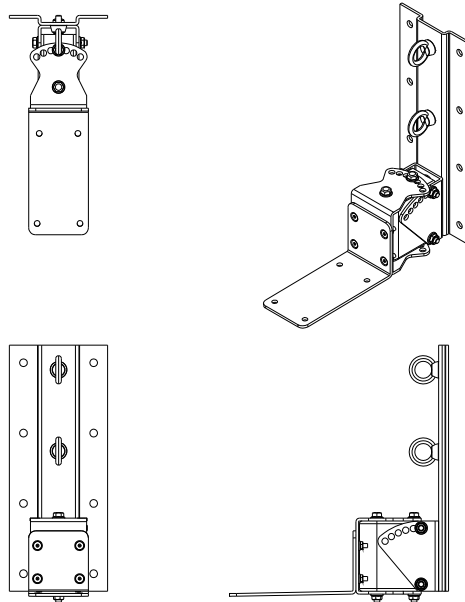

Figure 2

Prior to mounting the wall bracket to the wall the speaker mount section should be removed. See Figures 2a and 2b.

NOTE: The M10 bolts associated with the “pan” axis should be left in place, as shown in both Figures 2a and 2b.

The wall bracket section should now be mounted to the wall surface. The PT-70-2 has 12 mounting holes and the PT-35-2 has 8 mounting holes for allowing fasteners to join the bracket and loudspeaker assembly to the mating surface.

**IT IS NECESSARY TO USE ALL MOUNTING HOLES TO INSURE A SAFE AND SECURE MATE TO THE ASSOCIATED SURFACE! (12 for the PT-70-2 and 8 for the PT-35-2)**

All fasteners associated with the mounting of the Pan and Tilt bracket and loudspeaker assembly to the mating surface are the responsibility of others. The design and structural capacity of mating surfaces (such as walls) vary greatly and specific fasteners are designed for use with specific mating surfaces. One Systems does not recommend any mating fasteners and strongly urges the installer to consult with one experienced in suspension of products from the specific mating surfaces and the appropriate choice of fasteners for those specific surfaces.

The wall bracket section should be secured firmly to the mating surface using the appropriate fastening system. The fastening system should be determined by the structure of the mating surface.

IT IS CRITICAL THAT THE MATING SURFACE BE CAPABLE OF SUPPORTING THE LOAD OF THE PT BRACKET, THE LOUDSPEAKER AND ALL SUSPENSION HARDWARE, AS WELL AS PROVIDING THE PROPER SAFETY FACTORS. DO NOT ATTEMPT TO SUSPEND THE BRACKET AND LOUDSPEAKER UNTIL THE STRUCTURAL CHARACTERISTICS OF THE MATING SURFACE ARE UNDERSTOOD. DO NOT INSTALL THE PT BRACKET AND LOUDSPEAKER IF THE MATING SURFACE IS NOT CAPABLE OF SUPPORTING THE ENTIRE ASSEMBLY WEIGHT, AS WELL AS PROVIDING THE REQUIRED SAFETY FACTORS!

After the PT wall section of the bracket is securely mounted to the mating surface, the loudspeaker section should be mounted to the loudspeaker using the fasteners supplied. (DO NOT SUBSTITUTE FASTENERS) The loudspeaker mount section of each bracket is shown in figures 2a and 2b.

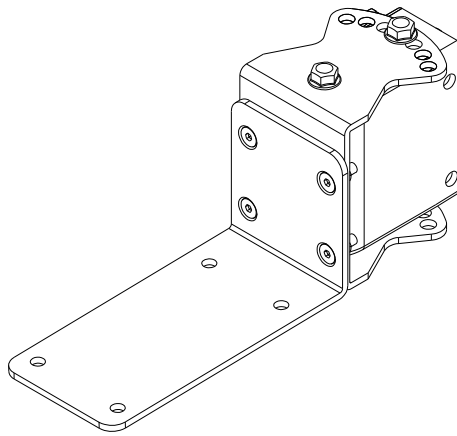

Figure 2a PT-35-2 speaker mount bracket

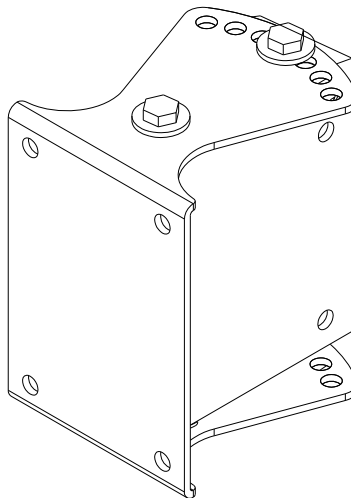

Figure 2b PT-70-2 speaker mount bracket

The PT-70-2 mounts to the rear of ALL IM series enclosures, except for the 108IM and 208CIM, using the 140mm x 90mm M10 locations as shown in figure 2c. The PT-35-2 mounts to the top or bottom of the 108IM or 208CIM as shown in figure 2c using the M8 locations. The mounting locations are highlighted in red.

**DO NOT SUBSTITUTE MOUNTING LOCATIONS!**

NOTE: There are 8 each hex head M10 bolts supplied in the mounting kit of the PT-70-2. When mounting the 115TW, 112UM and 115UM (wood) enclosures to the PT-70-2 use 4 each of the 45mm (longer) M10 bolts. The 4 shorter M10 bolts are used for the IM series injection molded enclosures.

Additionally, there are forged shoulder eyebolts supplied in the PT kits, 2 each M10 eyebolts for the PT-70-2 and 1 each M8 eyebolt for the PT-35-2. One of these eyebolts must be installed in the top, rear portion of the enclosure. When installing the PT-70-2, use the longer of the two M10 eyebolts for wood enclosures and the shorter of the two M10 eyebolts for the IM series enclosures. Make sure that the eyebolt is seated on the surface of the enclosure.

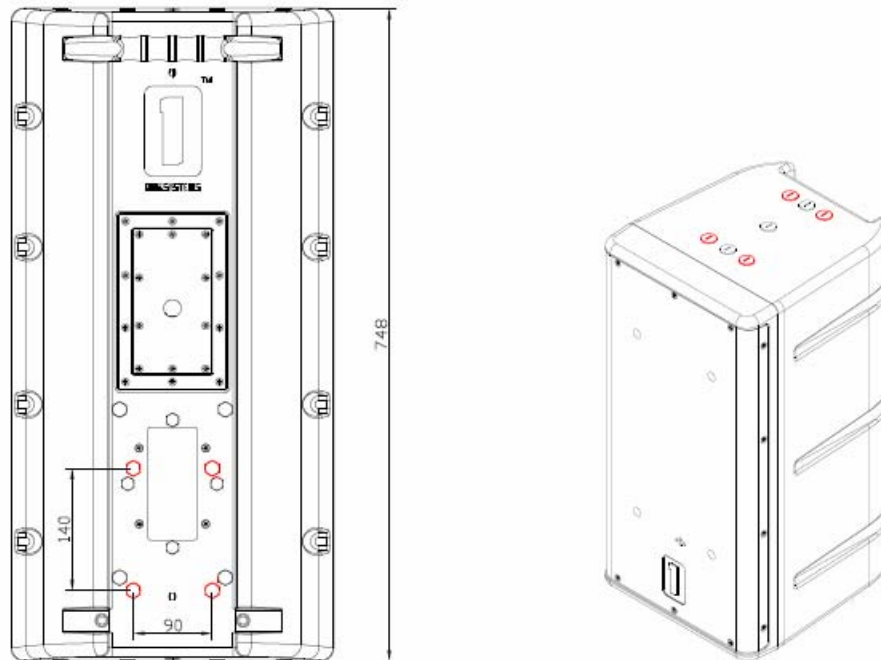

Figure 2c

The loudspeaker and loudspeaker section of the bracket may now be joined to the wall section and the required pan and tilt angles selected. This is a two person job and extreme care should be exercised to avoid serious injury.

The M10 tilt pivot bolt should be inserted first and secured but not completely tightened using the nylon insert M10 nuts supplied. The tilt pivot bolt is shown below in Figure 2d. Then the M10 tilt aiming bolt should be inserted and nylon insert nuts applied. Then the tilt axis bolts should be tightened.

**CAUTION: DO NOT REMOVE THE PAN PIVOT BOLT**

Next the pan angle may be adjusted by removing the M10 pan aiming bolt, but NOT the pan pivot bolt, and setting the desired pan angle and then re inserting the M10 bolt.

Once both the tilt and pan angles are set, make sure that all bolts are tight and secure.

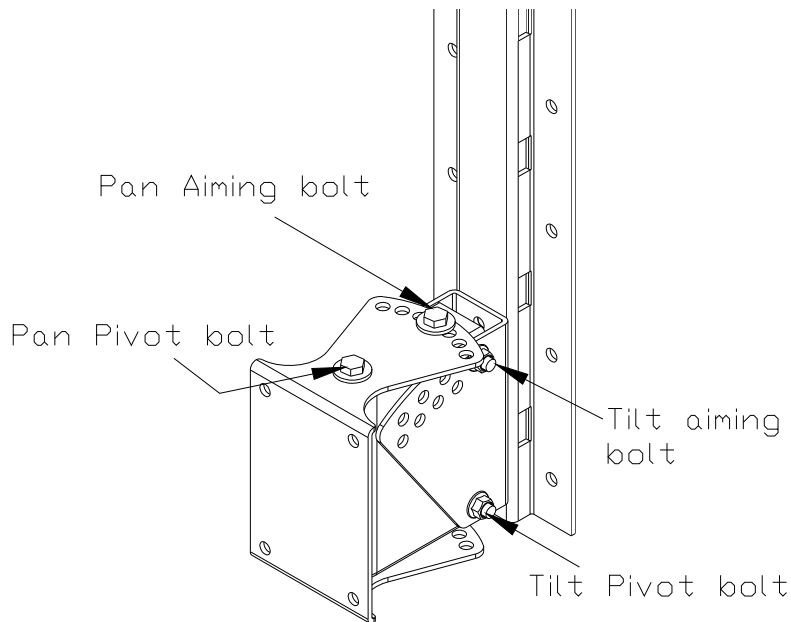

Figure 2d

**INSTALLING THE LINK**

Figure 3 is a representation of the Link assembly. This assembly **MUST** be used whenever the PT-70-2 or PT-35-2 is being used. Each pan and tilt bracket is supplied with a link assembly. (The 112UM does NOT use the Link and requires a user supplied wire rope assembly in place of the LINK!)

**SEE SECTION 5 OF THIS MANUAL FOR DETAILS ON THE PROPER MOUNTING OF THE LINK ASSEMBLY!**

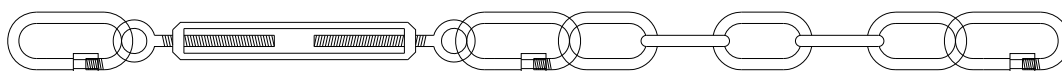

Figure 3

## POLE MOUNTING THE WITH THE PT-70 AND PT-35

Prior to mounting the wall bracket to the pole the speaker mount section should be removed. (See Figures 2a and 2b)

NOTE: The M10 bolts associated with the “pan” axis should be left in place, as shown in both Figures 2a and 2b.

### CAUTION: DO NOT REMOVE THE PAN PIVOT BOLT

The PT-70-2 and PT-35-2 also have slots cut in the wall mount section of the bracket that allow the brackets to be pole mounted. The pole mount section requires that BAND-IT brand stainless steel bands be used.

For the PT-70-2, rectangular poles must have a flat mounting surface of at least 5.5 inches (140mm) for mounting. Circular poles must have a diameter of at least 8 inches (203mm).

For the PT-35-2, rectangular poles must have a flat mounting surface of at least 5.5 inches (140)mm. Circular poles must have a diameter of at least 4 inches (101)mm.

IMPORTANT: Figure 4 shows the PT-70-2 with slots visible. The slots are shown in red. There are 5 slots and ALL 5 slots must be utilized for secure mounting to a pole. Each of the 5 slots must use double wrapped BAND-IT bands as described in step 1 below.

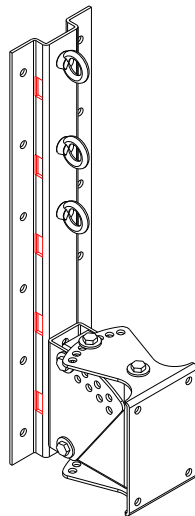

Figure 4

Figure 5 shows the PT-35-2 with slots visible.

**IMPORTANT:** There are 3 slots, shown in red. Each of the 3 slots must be utilized to insure a secure mount to a pole. ALL 3 slots must use double wrapped bands!

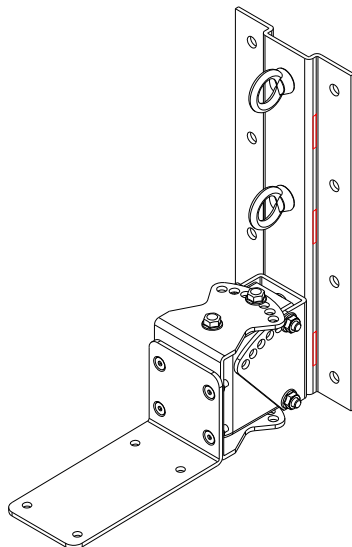

Figure 5

1. Mount the wall bracket section (see figure 1a) of the bracket to the pole at the desired height on the pole. The bracket is mounted to the pole using BAND-IT stainless steel bands. DO NOT SUBSTITUTE bands of other material or other widths! There are five locations on the pole bracket for bands. ALL 5 LOCATIONS MUST BE USED on the PT-70-2. There are 3 locations for the PT-35-2 and ALL 3 slots MUST BE USED. Figure 6 below illustrates the locations for the stainless steel band clamps.(PT-70 is shown)

It is REQUIRED that ALL bands be DOUBLE wrapped. Double wrapping will insure a strong and secure mounting of the bracket to the pole. The stainless steel banding materials should be as follows:

BAND-IT	# C206R9 stainless steel bands
BAND-IT	# C25699 buckles
BAND-IT	# C00169 tensioning tool

The stainless steel band is Type 201SS 0.030 inches (0.762mm) thick and 0.750 inches (19mm) wide.

**WARNING:** Do NOT substitute banding materials or banding dimensions.

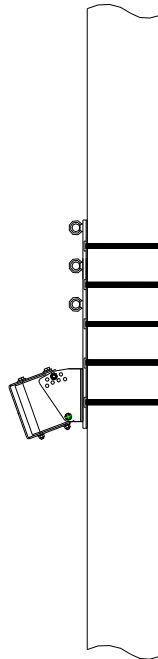

Band-It Stainless Steel  
band and clamp  
assemblies  
5 each  
#C206R9 band  
#C25699 buckle

Figure 6  
PT-70-2 bracket shown

Installation instructions from BAND-IT should be followed exactly. Operating instructions are supplied with the tensioning tool. (All BAND-IT parts and tools purchased separately. These parts and tools are not supplied by ONE SYSTEMS)

The stainless steel banding materials, buckles and tensioning tools are available from the following locations (or through distributors recommended by these locations):

BAND-IT IDEX, Inc.  
4799 Dahlia St.  
Denver Colorado 80216  
USA  
1-800-525-0758

P&C Industrial Supplies  
1-800-922-9291  
(P&C is an authorized U.S.A. Distributor for Band-It Products)

FELIX PONCE  
Calle Ignacio Zaragonza No. 8  
Colonia Ahuehuetes Atizapan 52953  
Edo. de Mexico  
(52) 555825 8502

BAND-IT Company Limited  
Speedwell Industrial Estate

Stavely, Nr. Chesterfield  
Derbyshire, S43 3PF England  
Home Sales (44) 1246-479479  
Export Sales (44) 1246 479480

BAND-IT Clamps (ASIA) Pte. Ltd.  
11 Second Chin Bee Road  
Singapore 618777  
65-62658853

BAND-IT Shanghai Sales Office  
207 room  
Wanbao International Business Centre  
660# Xinhua Road  
Shanghai, China 200052  
021-62826348-308

2. Next, the loudspeaker bracket should be mounted to the loudspeaker using the supplied M10 (M8 for the 108IM and 208CIM) stainless steel bolts and internal tooth lock washers. **DO NOT SUBSTITUTE ANY PARTS**
3. Now the M10 (M8 for 108IM and 208CIM) forged shoulder “eye” bolt should be installed in the top rear of the loudspeaker enclosure. Make sure that that eyebolt is seated on the enclosure surface.

NOTE: There two (2) forged shoulder eye bolts included. One has a 17mm threaded section and the second has a 40mm threaded section. Use the 17mm threaded section eye bolt for the 112IM, 212CIM, 212IM, 312CIM and CFA enclosures. Use the 40mm threaded section for the 115TW, 112UM, and 115UM wood enclosures.

4. The loudspeaker may now be placed on the pole bracket.

**USE EXTREME CAUTION!** The loudspeaker is heavy and it is likely that the desired mounting location is high in the air. This process should never be attempted by a single person.

TWO PEOPLE ARE REQUIRED TO MOUNT THE LOUDSPEAKER ENCLOSURE TO THE WALL, POLE AND PT bracket. Safety harnesses should always be worn when working from an elevated platform.

**CAUTION: DO NOT REMOVE THE PAN PIVOT BOLT (See Figure 2d)**

The M10 tilt pivot bolt should be inserted first and secured but not completely tightened using the nylon insert M10 nut supplied. The tilt pivot bolt is shown below in Figure 2d. Then the M10 tilt aiming bolt should be inserted and nylon insert nuts applied. Then the tilt axis bolts should be tightened.

Next the pan angle may be adjusted by removing the M10 pan aiming bolt, but NOT the pan pivot bolt, and setting the desired pan angle and then re inserting the M10 bolt.

Once both the tilt and pan angles are set, make sure that all bolts are tight and secure.

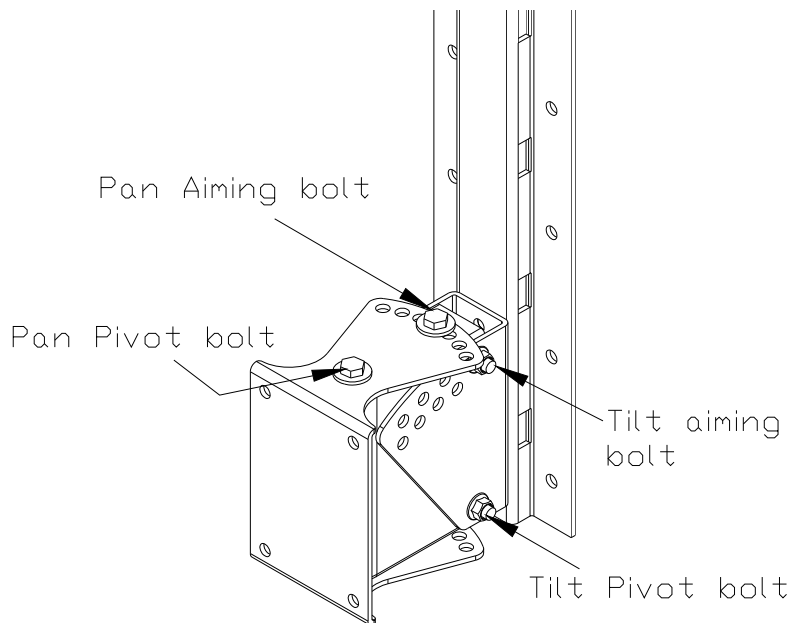

UNDER NO CIRCUMSTANCES SHOULD THE LOUDSPEAKER DOWN TILT EXCEED 35 DEGREES FROM VERTICAL FOR THE PT-70-2 (40 DEGREES FOR THE PT-35-2).

## SECTION 5 LINK ASSEMBLY

5. Now the Link must be installed.

INSTALLING the Pan and Tilt Brackets WITHOUT THE LINK IS NOT ALLOWED!

NOTE: The 112UM does not use the Link assembly for down tilt angles of 10 degrees or less from vertical. A user supplied wire rope assembly is required in place of the Link!

The Link (see figure 3) consists of stainless steel quick links, a stainless steel turnbuckle, and several links of stainless steel chain. The use of the chain pieces and quick links with the turnbuckle is based on the tilt angle of the enclosure. The turnbuckle should always be used.

**DO NOT SUBSTITUTE ANY PART OF THIS LINK ASSEMBLY!**

The Link should be tightened by rotating the turnbuckle until there is tension on the Link assembly. Do not over tighten. The purpose of the Link is to provide support for the main Pole Mount System tilting bracket at the bottom of the assembly.

The back plate sections of the PT-70-2 and PT-35-2 have eyebolts attached to them. There are 3 eyebolts on the back plate section of the PT-70-2 and 2 eyebolts on the back plate section of the PT-35-2. Figure 7 below illustrates which eyebolt should be used for each down tilt angle.

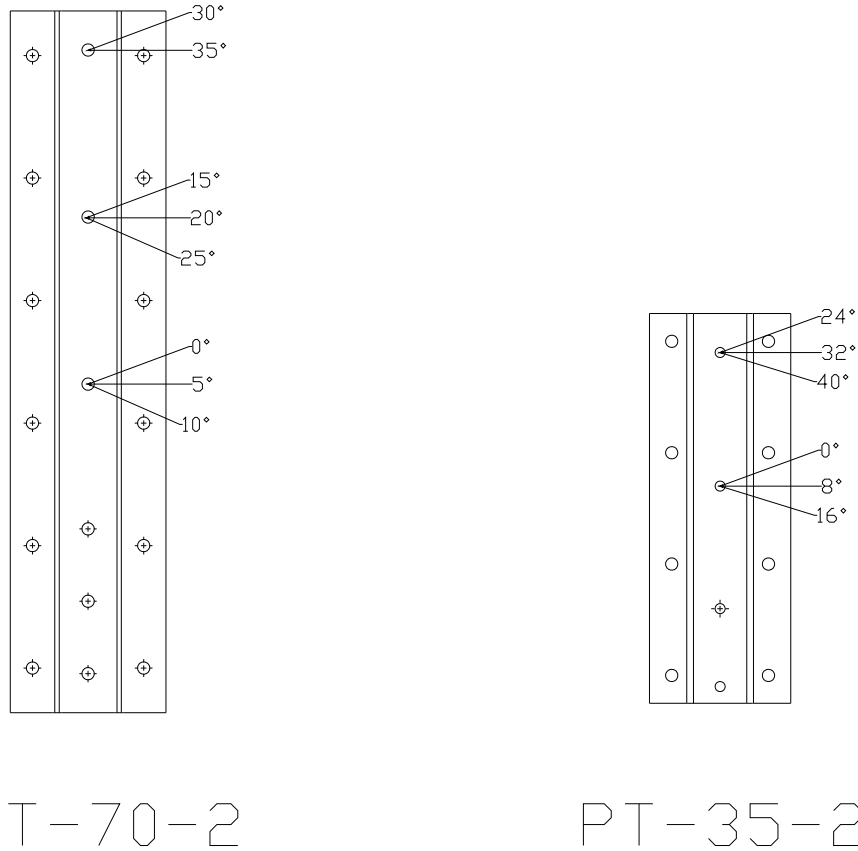

Figure 7

Make sure to use the appropriate combination of Link parts to insure proper connection between the Pole Mount System and the specific One Systems enclosure. The required combination of Link parts is determined by the down tilt angle of the enclosure.

The assembly may be configured with any combination of turnbuckle, chain link sections and quick link in order to achieve the proper tension on the system, but the turnbuckle must always be used. Figures 8a, 8b, and 8c show a 108IM and PT-35-2 at vertical, 24 degrees and 40 degrees using the eye bolt positions shown in Figure 7. Note that Figures 8a and 8b below use the same link and turnbuckle combination, but different eye bolt locations. Figure 8c below uses chain sections, as well as the quick links and the turnbuckle.

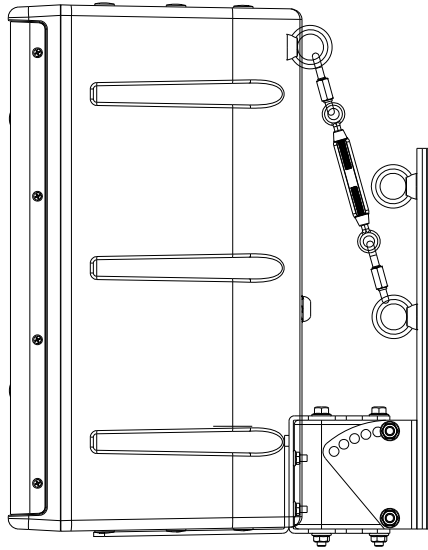

Figure 8a

Figure 8a represents the Link assembly with the enclosure in a vertical orientation and the Link using the lower eyebolt position.

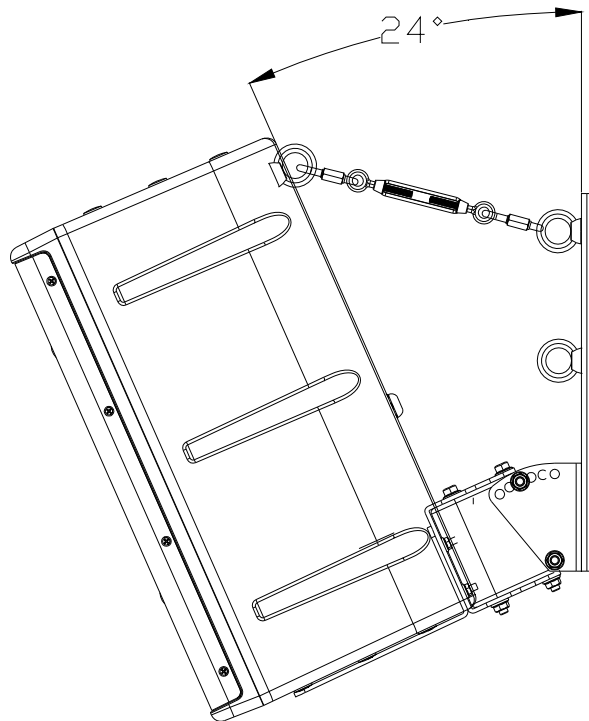

Figure 8b

Figure 8b above represents the Link with the enclosure in a 24 degree tilt. The Link is using the top eyebolt and the turnbuckle has been adjusted to provide mild tension.

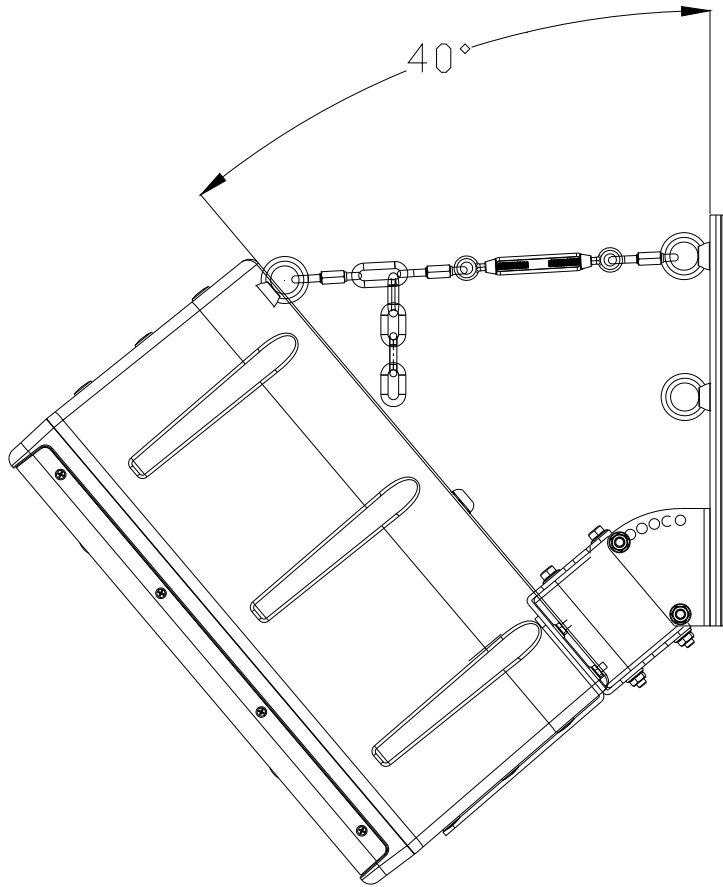

Figure 8c

Figure 8c above represents the Link assembly with the enclosure in a 40 degree tilt. The Link assembly uses the top eyebolt and the stainless steel chain has been added to achieve the proper tension on the assembly. Notice the “dropped” chain links in Figure 8c.

Warning, if the turnbuckle assembly is turned and the loudspeaker enclosure angle begins to change (if the down tilt angle begins to move toward 0 degrees vertical then the turnbuckle has been OVER TIGHTENED. Turn the turnbuckle until the down tilt angle is set by the M10 thru bolt on the pole bracket.

Figure 9 below shows a 312CIM mounted to a PT-70-2. The down tilt is 35 degrees so the top eyebolt is utilized as per Figure 7.

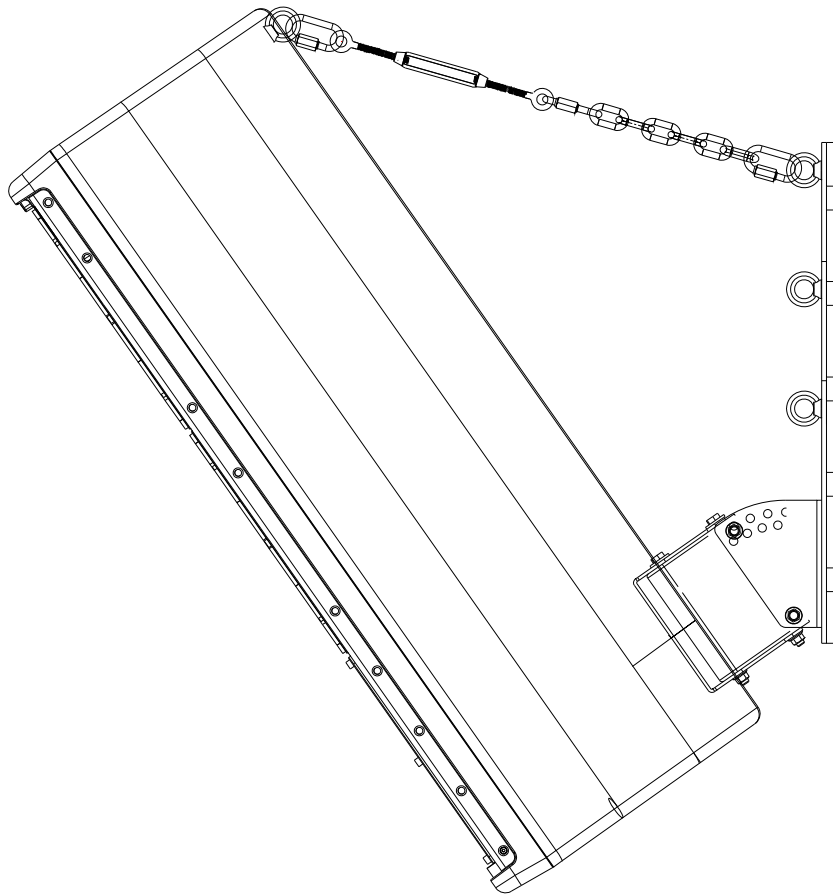

Figure 9

Figure 9 above represents the maximum down tilt angle of 35 degrees from vertical. Note that because the down tilt angle is 35 degrees the top eyebolt has been used, again per Figure 7.

Figure 10 below is a close up view of the Link assembly. Certain down tilt angles may require a link to be “dropped” from the chain as shown below. The lower quick link is positioned in various chain segments based on the desired degree of down tilt. The turnbuckle should be adjusted, as described in this section

In any position, the turnbuckle must be adjusted to allow the proper amount of tension on the Link. The Link should never pull the loudspeaker up towards vertical. The Link may be configured with or without the chain section and quick link depending on the down tilt angle of the enclosure.

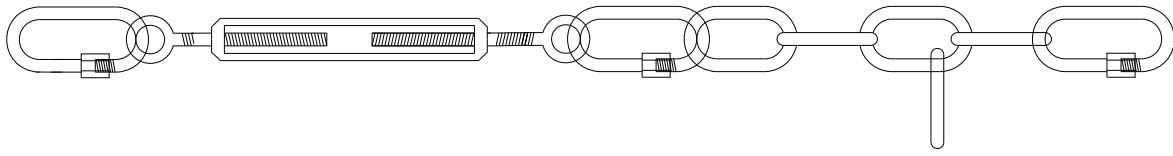

Figure 10

Secondary safety cables are **STRONGLY** recommended and should be secured to a structural point **NOT** associated with the PT bracket or loudspeaker.

## PT-10 Installation

The One Systems PT-10 is designed for use with the 103IM and 106IM family of One Systems products only.

### **DO NOT SUBSTITUTE OTHER LOUDSPEAKER ENCLOSURES!**

The PT-10 has been designed as a low cost yet flexible pan and tilt system and is intended for use with small format, low Q loudspeaker systems. The PT-10 offers 10 degree aiming increments and will provide up to 5 steps within the nominal 100 degree pattern of either the 103IM or the 106IM. Figure 11 below represents the PT-10 pan and tilt bracket.

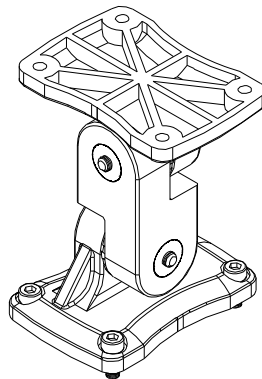

Figure 11

There are two center pieces that may be used for aiming with the PT-10 bracket. Each “center piece” offers aiming resolution of 20 degrees but substitution of the center pieces will yield aiming resolution of 10 degrees.

Figure 12a below shows the two center pieces. The 10 degree aiming resolution is achieved by substituting the appropriate center piece to achieve a **TOTAL** resolution of 10 degrees between the two center pieces. These two center pieces are interchangeable and may be used to set the desired angles.

Note the “rotated clock” section in “Part 2” of Figure 11a below. This section is rotated 10 degrees from the part labeled “Part 1” and is what allows the aiming increments to be adjusted in 10 degree steps.

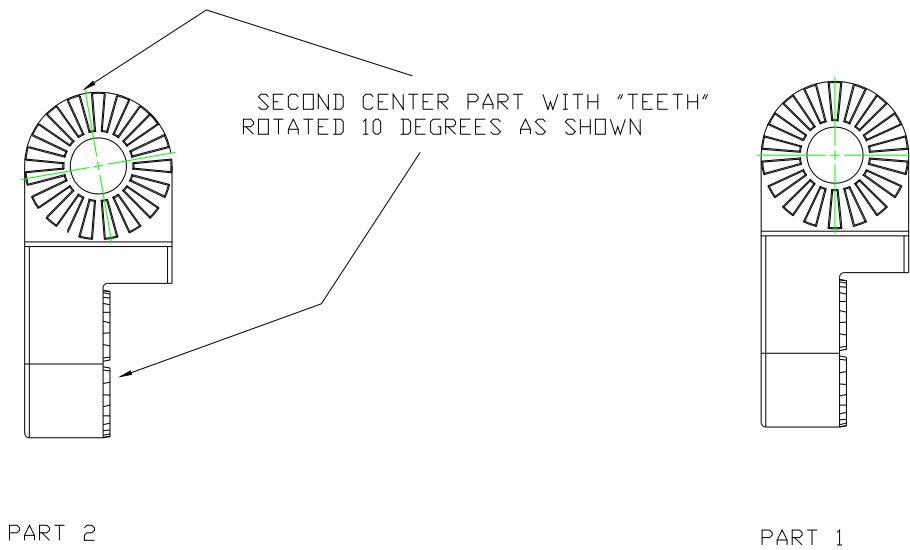

FIGURE 11a

Figure 12 below shows a One Systems 103IM mounted to a PT10. There are four (4) M5 stainless steel bolts that are supplied with the PT-10 for mounting to either the 103IM or the 106IM. Once the PT-10 is mounted to the specific loudspeaker enclosure the two stainless steel bolts on the center piece of the PT-10 may be loosened to allow the bracket to be rotated in both the “pan” and “tilt” axis. Once proper loudspeaker aiming is achieved both of these bolts must be securely fastened to insure the assembly will not move.

**NOTE:** It is strongly recommended that a “temporary” thread locker be used to secure the two M6 bolts that set both the pan and the tilt angles of the PT-10.

**NOTE:** Security bolts are available from One Systems for use in place of both the M5 and M6 bolts that are supplied with the PT-10

It is necessary to fit an additional safety assembly between the loudspeaker enclosure and the mounting surface. **This safety assembly is not supplied by One Systems.** The safety assembly must conform to local and national codes.

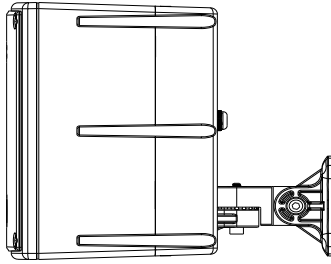

Figure 12

Secondary safety cables are **STRONGLY** recommended and should be secured to a structural point **NOT** associated with the PT bracket or loudspeaker.

## APPENDIX 1 (Projected Area Values)

The values below should be supplied to the specific pole manufacturer for safety calculations. These values were determined by adding the projected areas of the high frequency horns, the woofer cones and ports to the cross sectional area of the front of each enclosure listed below.

103IM .....	67 in <sup>2</sup> (43,000mm <sup>2</sup> )
106IM.....	136 in <sup>2</sup> (88,000mm <sup>2</sup> )
108IM.....	250 in <sup>2</sup> (161,290mm <sup>2</sup> ) (60x40 HF horn)
208CIM.....	207 in <sup>2</sup> (133,550mm <sup>2</sup> )
112IM .....	600 in <sup>2</sup> (387,096 mm <sup>2</sup> ) (60x40 HF horn)
212CIM.....	600 in <sup>2</sup> (387,096mm <sup>2</sup> )
212IM .....	804 in <sup>2</sup> (550,000 mm <sup>2</sup> )
312CIM.....	804 in <sup>2</sup> (550,000mm <sup>2</sup> )
Cross Field Array.....	2,708in <sup>2</sup> (1,750,000mm <sup>2</sup> )